

# API800 Series Bottom Loading Coupler

API bottom loading dry-break coupler with automatic latching.  
Built with a stainless steel latch release handle and coming in at 8.5kg the slimline Liquip API800 Series coupler is impressive by any measure.  
With a robust design and ease of servicing, customers will experience effortless bottom loading. Liquip has considered each detail of the coupler with the user in mind to maximise the safety, performance, service life and quality of the coupler.

## Key Features

- Fast in-field replacement of all seals on or off the arm
- A range of seals for use to suit a range of applications.
- Two operating handle sizes to suit various applications.
- 4 true interlocking stainless steel latches for secure coupling and maximum safety.
- Stainless steel collar and hard anodised body for increased service life and durability.
- Stainless steel latch release handle for long term strength and durability.
- High quality components for increased operating life.
- Increased site safety via minimal product leakage during disconnect.
- Vastly reduced risk of leakage through new sealing design.
- Improved ergonomic operating handle and carry loop during use with less physical strain on users.



## Ordering Information

<b>API810</b> Short Handle, Viton B70	<b>API812</b> Long Handle, Viton B70	<b>API822</b> Long Handle Drip Catcher, Viton B70
<b>API810VG</b> Short Handle, Viton GFLT	<b>API812VG</b> Long Handle, Viton GFLT	<b>API822VG</b> Long Handle Drip Catcher, Viton GFLT
<b>API810C</b> Short Handle, FFKM	<b>API812C</b> Long Handle, FFKM	
	<b>API812G</b> Long Handle, AVGAS Selective	
	<b>API812J</b> Long Handle, Jet Selective	

Note: Please see overleaf for other seal options and for a list of spare parts available.

## Specifications

<b>Handle Length</b>	Short (150mm) or Long (200mm)
<b>Seals</b>	Standard with either Viton B, Viton GFLT, FFKM (Fluorosilicone and Buna seals also available)
<b>Max Working Pressure</b>	550 kPa
<b>Product Test Pressure</b>	820 kPa
<b>Design Pressure</b>	2500 kPa
<b>Max Surge Pressure</b>	3400 kPa
<b>Operating Temperature</b>	-20°C to +80°C (-4°F to + 176°F) -40°C to +60°C (-40°F to + 140°F)
<b>Design Standard</b>	API RP 1004 8th EDITION 2003 - Bottom Loading and Vapour Recovery
<b>Dismantling</b>	Removal of one roll pin enables the shaft assembly and main poppet to be withdrawn
<b>Mounting</b>	<ul style="list-style-type: none"> <li>• By industry standard 100mm (4") TTMA Flange</li> <li>• 8 holes Ø11mm on 149mm PCD, 168 outside diameter (Ø7/16" on 5.8" PCD, 6.6" OD)</li> <li>• Use spring washers when mounting coupler as per common industry practice</li> </ul>
<b>Adjustment or Service</b>	Refer to Maintenance Instructions document.
<b>Weight</b>	8.5kg

## Spare Parts

The table below lists common spare parts for the API800 series.

Part Number	Spare Part Description	Contents	Quantity required*
API800SKZ	API800 All seal kit (Viton B)	1.00 x API800-1 Product Seal (Viton B) 1.00 x 0203 Outer O-ring (Viton B) 1.00 x 5805 Grease Kit 1.00 x API800-7A	1
API800VGSKZ	API800 All seal kit (Viton GFLT)	1.00 x API800-1VG Product seal (Viton GFLT) 1.00 x 0203VG outer o-ring (Viton GFLT) 1.00 x 5805 Grease Kit 1.00 x API800-7AVG	1
API8KITZ	API800 Poppet Seal/O-ring Kit (Viton B)	1.00 x API800-1 Product Seal (Viton B) 1.00 x 0203 Outer O-ring (Viton B) 1.00 x 5805 Grease Kit	1
API8VGKITZ	API800 Poppet Seal/O-ring Kit (Viton GFLT)	1.00 x API800-1VG Product seal (Viton GFLT) 1.00 x 0203VG outer o-ring (Viton GFLT) 1.00 x 5805 Grease Kit	1
API800-7A	Bush and O-ring assembly (Viton B)	1.00 x Bush and O-ring assembly (Viton B) 1.00 x Nyloc Nut (4955) 1.00 x 55074 (circlip internal) 2.00 x 55075 (circlip internal)	1
API800-7AVG	Bush and O-ring assembly (Viton GFLT)	1.00 x Bush and O-ring assembly (Viton GFLT) 1.00 x Nyloc Nut (4955) 1.00 x 55074 (circlip internal) 2.00 x 55075 (circlip internal)	1
API800-7AC	Bush and O-ring assembly (FFKM)	1.00 x Bush and O-ring assembly (Viton FFKM) 1.00 x Nyloc Nut (4955) 1.00 x 55074 (circlip internal) 2.00 x 55075 (circlip internal)	1
API800-1	Product Seal (Viton B)	1.00 x Seal Product (Viton B)	1
API800-1VG	Product Seal (Viton GFLT)	1.00 x Seal Product (Viton GFLT)	1
API800-1K	Product Seal (FFKM)	1.00 x Seal Product (FFKM)	1
API800-1F	Product Seal (Fluorosilicone)	1.00 x Seal Product (Fluorosilicone)	1
API800-1NBR	Product Seal (Buna)	1.00 x Seal Product (Buna)	1
0203B	O-ring (Buna)	1.00 x O-ring for poppet adaptor ring (Buna)	1
0203	O-ring (Viton B)	1.00 x O-ring for poppet adaptor ring (Viton B)	1
0203VG	O-ring (Viton GFLT)	1.00 x O-ring for poppet adaptor ring (Viton GFLT)	1
0203K	O-ring (FFKM)	1.00 x O-ring for poppet adaptor ring (FFKM)	1
55072	Spring Roll Pin for Eccentric Cam	1.00 x Spring Roll Pin (For Eccentric Cam)	1
6182	Wave Spring	1.00 x Wave Spring	1
0762	Split Pin	1.00 x Split Pin	4
API725-4Z	Latch Collar Interlock Kit	4.00 x Latch Collar Interlock 4.00 x Latch spring 4.00 x Latch Pin	4
0927	Spring Roll Pin for latches	1.00 x Spring (Roll) Pin (for Latches)	4

\*Quantity required for applicable models.

### **SPECIAL NOTES FOR SPARE PARTS**

#### **API800-7A and API800-7AVG**

- If your coupler operating handle is fitted two circlips (55075), disregard the Nyloc Nut (4955)
- If your coupler operating handle is fitted with a Nyloc Nut (4955), disregard the two smaller circlips (55075).



# API800 SERIES COUPLERS

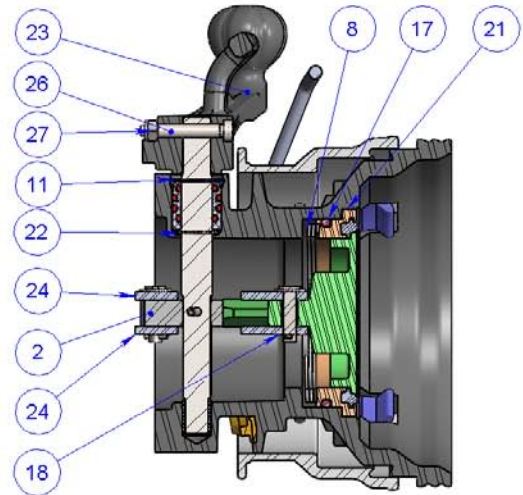
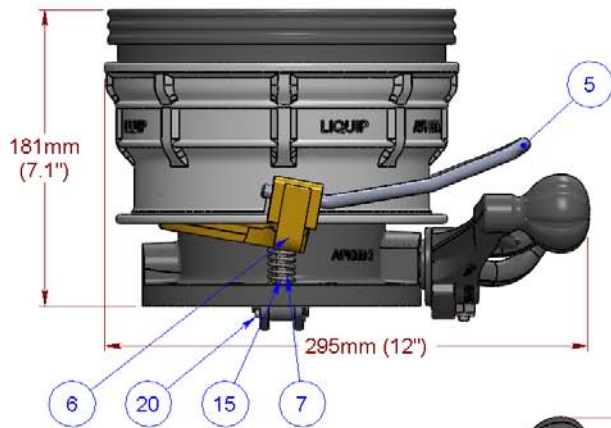

SECTION A-A

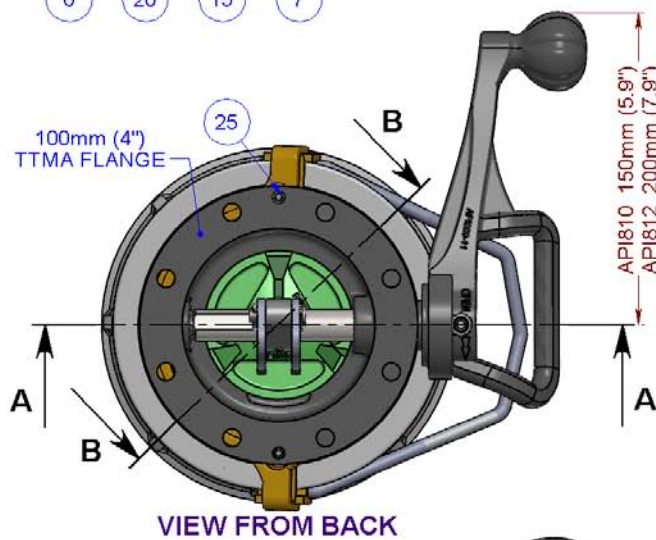

VIEW FROM BACK

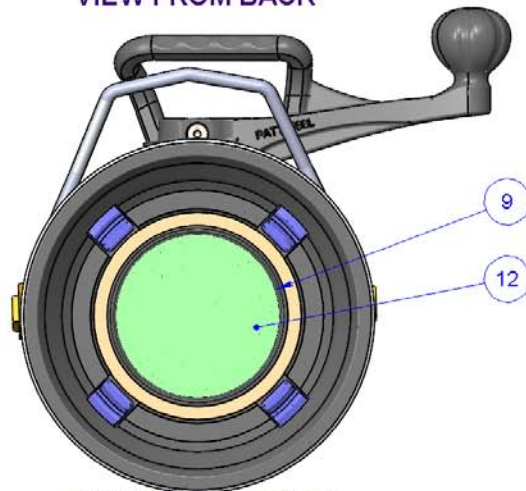

VIEW FROM OUTLET

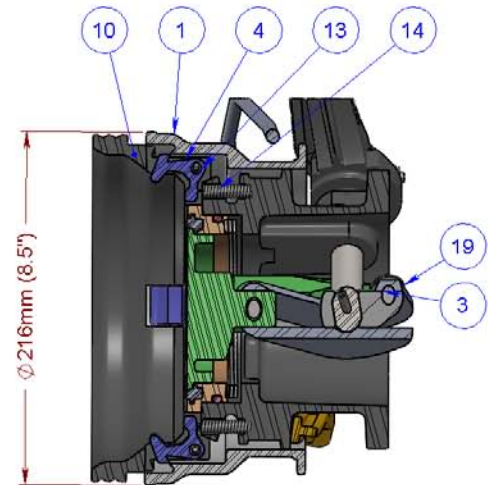

SECTION B-B

NOTE: API812- LONG STYLE  
OPERATING HANDLE SHOWN

# API800 SERIES COUPLERS

ITEM NO.	PART NUMBER	DESCRIPTION	API810	API812	API810VG	API812VG	MATERIAL
1	API800-3	OUTER BODY (COLLAR)	1	1	1	1	ST STEEL
2	API800-8	CAM ECCENTRIC	1	1	1	1	ST STEEL
3	API800-12	PIN CLEVIS	2	2	2	2	STEEL PHOSPHATED
4	API725-4	LATCH COLLAR INTERLOCK	4	4	4	4	ST STEEL
5	API555-6	HANDLE - OUTER BODY RING	1	1	1	1	ST STEEL
6	API555-10	LEVER OUTER BODY	1	1	1	1	ALUMINIUM
7	API800-13	PIN - SPRING RETURN	2	2	2	2	ST STEEL
8	6182	SPRING SPIRAWAVE	1	1	1	1	SPRING STEEL
9	API800-1	SEAL PRODUCT	1	1	-	-	VITON B
	API800-1VG	SEAL PRODUCT	-	-	1	1	VITON GFLT
10	API800-2	BODY API800 COUPLER	1	1	1	1	ALUMINIUM
11	55074	CIRCLIP INTERNAL	1	1	1	1	ST STEEL
12	API800-9	POPPET 4"	1	1	1	1	ALUMINIUM
13	0927	SPRING (SELLOK) PIN	4	4	4	4	Z/P STEEL
14	6171	SPRING COMPRESSION	4	4	4	4	ST STEEL
15	4497	SPRING - RETURN	2	2	2	2	SPRING STEEL
16	55072	SPRING (SELLOK) PIN	1	1	1	1	ST STEEL
17	0203	O-RING	1	1	-	-	VITON B70
	0203VG	O-RING	-	-	1	1	VITON GFLT
18	5351	WASHER FLAT THIN	2	2	2	2	ST STEEL
19	0101	WASHER FLAT	2	2	2	2	Z/P STEEL
20	0762	SPLIT COTTER PIN	4	4	4	4	ST STEEL
21	API800-4	POPPET ADAPTOR RING	1	1	1	1	ALUMINIUM
22	API800-5A	SHAFT AND BUSH ASSY	1	1	-	-	STEEL, VITON A & ACETAL
	API800-5AVG	SHAFT AND BUSH ASSY	-	-	1	1	STEEL, VITON GFLT & ACETAL
23	API800-15	SHORT STYLE HANDLE OPERATING	1	-	1	-	ALUMINIUM
	API800-11	LONG STYLE HANDLE OPERATING	-	1	-	1	ALUMINIUM
24	API800-6	CAMPLATE FOR API COUPLERS	2	2	2	2	STEEL PHOSPHATED
25	3227	GRUBSCREW MET	2	2	2	2	BLK STEEL
26	55091	CAPSCREW SHOULDER METRIC	1	1	1	1	STEEL PHOSPHATED
27	4399	NUT NYLOC	1	1	1	1	Z/P STEEL



# API800 SERIES COUPLERS

